

# Critical Cover® Coverall® Face Shields

## Splash Protection

**Features and Benefits:** When you need total facial splash protection, choose the Coverall® Face Shield. The face shield's wrap-around design provides the wearer with great peripheral vision while acting as a protective shield against non-hazardous liquid splash and light particles in a Lab or Controlled Environment. The Coverall® Face Shield is not ANSI Z87 rated for eye protection. You can wear the lightweight shield comfortably for long periods and it fits easily over prescription glasses or protective eyewear.

A double-sided anti-fog coating reduces the possibility of fogging in high humidity environments. For safe working conditions, the face shield is low distorting and 100% optically clear while a soft polyurethane foam headband securely positions the device on the wearer.

**Available in two styles:** Full face shield and half face shield. Also available with an adjustable Velcro® band, elastic Comfort headband or elastic headband with snaps.



*Anti-fogging*

### Coverall® Full Face Shields

- 2802 Full Face Shield w/Velcro Adjustable Band
- 2807 Full Face Shield w/Comfort Band

Individually Packaged  
100/case (4 boxes of 25)

- 1814 Full Face Shield w/Elastic Headband

Individually Packaged  
100/case (4 boxes of 25)

- 1814NB Full Face Shield w/Elastic Headband  
100/case (4 boxes of 25)



*Anti-fogging*

### Coverall® Half Face Shields

- 2803 Half Face Shield w/Velcro Adjustable Band
- 2808 Half Face Shield w/Comfort Band

Individually Packaged  
100/case (4 boxes of 25)

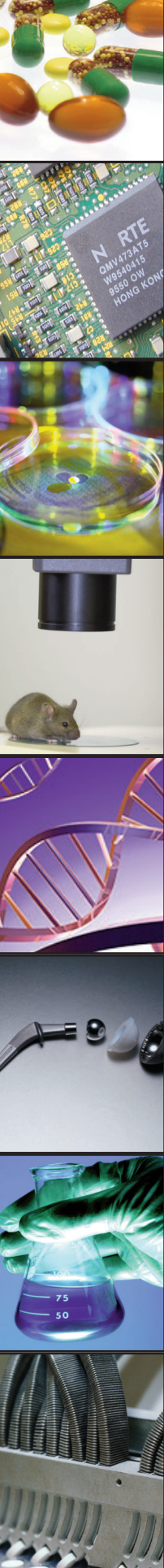

# Critical Cover® Coverall® Face Shields

## COVERALL® Full & Half Face Shields Specification Sheet

The single-use Coverall® Full & Half Face Shields are designed to protect the user's face. These shields can fit comfortably over glasses. The optically clear shield is 7-mil thick and coated with an anti-fog coating. Vision is distortion free with low glare and full peripheral vision. Polyurethane foam along the top of the shield provides a comfortable cushion to the user's forehead.

### Material List:

- Shield: 7-mil clear polyester film
- Foam: Polyurethane strip
- Headband: **2802, 2803:** 3/4" wide adjustable Velcro band  
**2807, 2808:** 1" wide elastic Comfort band  
**1814 & 1814NB:** 1/2" wide Elastic band

**Packaging:** 25 shields per dispenser box, 4 dispenser boxes per case, 100 shields/case

### Reference Figure:

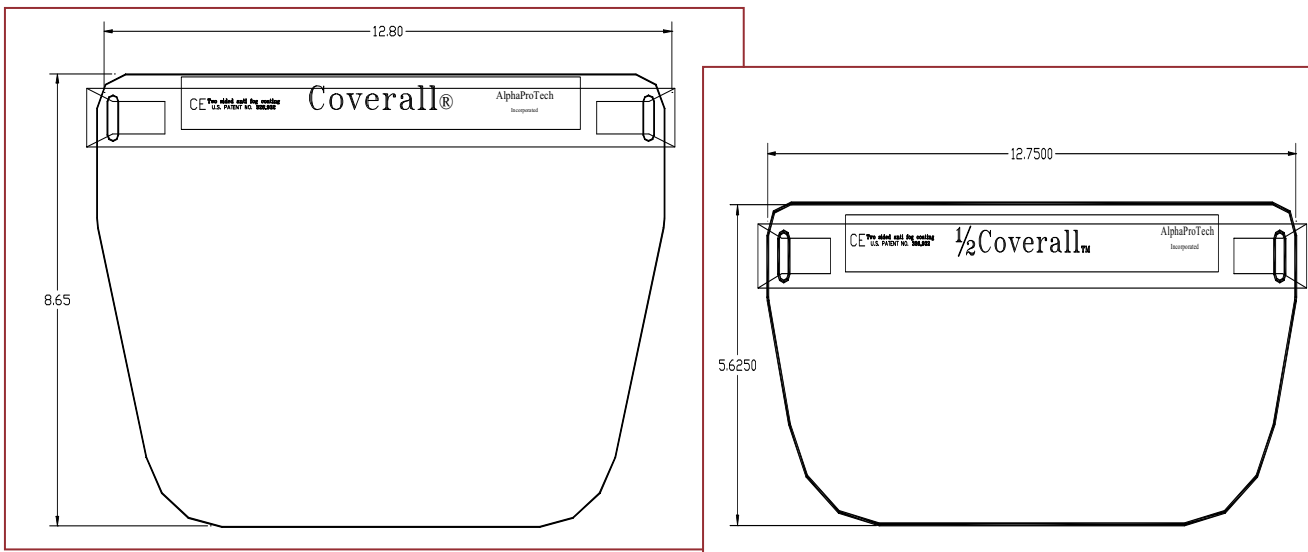

### Physical Properties Testing Chart

Standard Applied	Test Standard	Result
Helmke Drum	IEST-RP-CC003.3 <0.5um	Category I
Synthetic Blood Penetration	ASTM F1670	Pass
Water Resistance/Spray Impact	AATCC Method 42	<0.01g (pass)
Water Resistance/Spray Impact	AAMI PB70	<0.01g (pass)

Rev. C 4/20

As more fully set forth in the AlphaProTech Terms and Conditions of Sale, because conditions of use are out of AlphaProTech's control, AlphaProTech makes no warranties, expressed or implied, and assumes no liability as to the performance of these products for a particular use.

